



XM0



Control component with dynamic transducer and Modbus RTU interface

Compact device for use with VAV terminal units TVE

- Controller, dynamic differential pressure transducer and actuator in one casing
- Use in ventilation and air conditioning systems, only with clean air
- Simple terminal connection without the use of additional junction boxes
- Volume flow rates q_{vmin} and q_{vmax} are pre-set in the factory and saved in the controller as changed parameters
- High data transparency through standardised bus communication Modbus RTU, RS485
- Setpoint value settings, override controls, parameter adjustment via Modbus register
- Integrated display for volume flow rate display, operating mode display and setting of operating parameters
- Service access for manual adjustment devices and PC configuration software

General information	2	Variants	6
Function	3	Technical data	7
Specification text	4	Product details	13
Order code	5	Explanation	17

General information

Allgemeine Information 01

Application

- All-in-one control devices for VAV terminal units
- Dynamic differential pressure transducer, electronic controller, and actuator are fitted together in one casing
- Suitable for different control tasks depending on the specification of the setpoint value
- The room temperature controller, central BMS, air quality controller or similar units control the variable volume flow control by specifying the setpoint values via a communication interface or analogue signal
- Override controls for activating q_{vmin} , q_{vmax} , shut-off, OPEN position via Modbus register or switch/ relay possible
- Volume flow rate actual value is available as a network data point or linear voltage signal
- Damper blade position is available as a network data point
- Standard filtration in comfort air conditioning systems allows for use of the controller in the supply air without additional dust protection.

With heavy dust levels in the room

- Install appropriate exhaust air filters upstream, as a partial volume flow is routed through the transducer for volume flow rate measurement.

If the air is contaminated with dust, fluff or sticky components:

- Use of the XS0 module instead of the XMO compact controller described here

Allgemeine Information 02

Control concept

- The volume flow controller works independent of the duct pressure
- Differential pressure fluctuations do not result in permanent volume flow rate changes
- To prevent the control from becoming unstable, a dead band is allowed within which the damper blade does not move.
- Flow rate range parameterised in the controller at the factory (q_{vmin} : minimum volume flow rate, q_{vmax} : maximum volume flow rate)
- Operating parameters are specified via the order code and parameterised in the factory

Allgemeine Information 03

Operating modes

- Modbus (M): setpoint value specification via Modbus register
- Analogue – variable operation (V): setpoint value specification via analogue interface, signal voltage range corresponds to q_{vmin} to q_{vmax}
- Analogue – constant value mode (F): no setpoint value signal required, setpoint value corresponds to q_{vmin}

Allgemeine Information 04

Interface

Communication interface

- Modbus RTU, RS485
- For data points, see Modbus register list

Analogue interface with adjustable signal voltage range

- Analogue signal for volume flow rate setpoint value
- Analogue signal for volume flow rate actual value (factory setting)
- Alternatively: analogue signal for damper blade position (adjustment by others required)

Note:

- Interface type according to operating mode pre-set in the factory
- Can be adjusted by others using the communication interface (Modbus register) or display panel.

Allgemeine Information 05

Signal voltage ranges

When using the analogue interface

- 0 – 10V DC
- 2 – 10V DC

Allgemeine Information 06

Parts and characteristics

- Transducer for dynamic measurement principle
- Overload protection
- Terminals with cover
- Display and operating elements for simple menu guidance
- Menu guidance for adjusting operating parameters and communication interface
- Service interface

Allgemeine Information 07

Construction

- TROVM-024T-05I-DD15-MB
- Can only be used for type TVE

Allgemeine Information 08

Commissioning

- Due to the volume flow rates set in the factory, always ensure that the control units are only installed in the specified locations
- Analogue interface: ready for use after installation and wiring
- Modbus interface: additional commissioning steps required
- Operating parameters can be adjusted by the customer (using the display panel, adjustment device or Modbus register)

Allgemeine Information 09

Useful additions

- Adjustment device type GUIV3-M (order code AT-VAV-G3)

Function

Funktionsbeschreibung

A closed control circuit for regulation of the volume flow rate, i.e. measuring - comparing - adjusting, is characteristic of air terminal units.

The volume flow is measured by measuring a differential pressure (effective pressure). This is done via a differential pressure sensor. An integrated differential pressure transducer converts the effective pressure into a voltage signal. The volume flow rate actual value is hence available as a voltage signal. The

factory setting is such that 10 V DC always corresponds to the nominal volume flow rate (q_{vnom}).

The volume flow setpoint is specified by a higher-level controller (eg room temperature controller, air quality controller, building control system). Variable volume flow control results in a value between q_{vmin} and q_{vmax} . It is possible to override the room temperature control, e.g. by a complete shut-off of the duct. The controller compares the volume flow rate setpoint value to the actual value and controls the integral actuator accordingly.

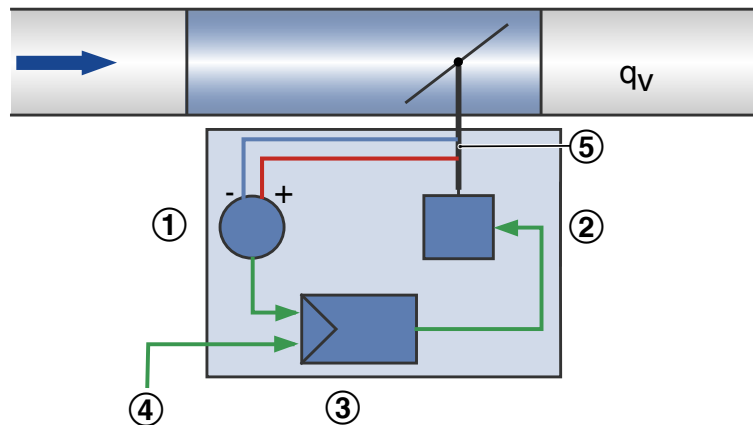

- ① Differential pressure transducer
- ② Actuator
- ③ Volume flow controller

- ④ Setpoint via Modbus or analogue signal
- ⑤ Shaft with effective pressure channel

Specification text

This specification text describes the general properties of the product.

Ausschreibungstext

Category

- Compact controller for volume flow rate.
- Regulation of a constant or variable volume flow rate setpoint
- Electronic controller for connecting a controlled variable and tapping an actual value for integration in the central building management system
- The actual value relates to the nominal volume flow rate such that commissioning and subsequent adjustment are simplified

Ausschreibungstext 02

Application

- Dynamic transmitter for clean air in ventilation and air conditioning systems
- Modbus commands (Modbus operating mode)
- External switch contacts/wiring (with analogue interface)

Ausschreibungstext 03

Supply voltage

- 24 V AC / DC

Ausschreibungstext 04

Actuator

- Integrated; slow running (running time 100 s for 90°)

Ausschreibungstext 05

Installation orientation

- either direction

Ausschreibungstext 06

Interface/Control

- Modbus RTU (RS-485) or alternative analogue signals (0 – 10V or 2 – 10V DC) can be used
- Interface type pre-parameterised in the factory on the basis of the order code

Ausschreibungstext 07

Connection

- Terminals with cover by rubber cap, therefore no additional terminal box required
- Double terminal for supply voltage for easy further wiring of up to 3 controllers

Ausschreibungstext 08

Interface information

- Modbus: including volume flow rate setpoint value and actual value signal, damper blade position, override control
- Alternatively: volume flow rate setpoint value and actual value signal as analogue signal

Ausschreibungstext 09

Special functions

- Clearly visible external indicator light for signalling the functions: Set, not set, and power failure
- Display for actual values, parameterisation and for test functions
- Activation q_{vmin} , q_{vmax} , closed, open by: Modbus (with Modbus control), external switch contacts (with analogue control)

Ausschreibungstext 10

Parameter settings

- Parameters specific to VAV terminal unit parameterised at the factory
- Operating values: q_{vmin} , q_{vmax} and interface type parameterised in the factory
- Subsequent adjustment via display and control element directly on the device or with optional tools: adjustment device, PC software (wired in each case), in Modbus mode as well as via Modbus register access

Ausschreibungstext 11

Factory settings

- Electronic controller factory-mounted on the terminal unit
- Factory parameter settings
- Functional test under air; certified with sticker

Order code

TVE – D / 200 / D2 / XM0 / V 0 / qvmin – qvmax m³/h
 | | | | | | | | | |
1 2 5 6 7 8 9 10 11

1 Type
TVE VAV terminal unit

2 Acoustic cladding

No entry: none

D With acoustic cladding

3 Material

Galvanised sheet steel (Standard construction)

P1 Powder-coated RAL 7001, silver grey

A2 Stainless steel construction

5 Nominal size [mm]
100
125
160
200
250
6 Accessories

No entry: none

D2 Double lip seal both sides

G2 Matching flanges for both ends

Order example: TVE/100/D2/XM0/M/20-350 m³/h
Acoustic cladding
Material
Nominal size
Accessories
Attachment
operating mode
Volume flow rate

Without

Galvanised sheet steel

100 mm

Double lip seal both sides

Compact controller Modbus, dynamic transducer

Modbus RTU

20 – 350 m³/h

7 Attachments (control component)
XM0 Compact controller of dynamic transducer, Modbus RTU, display

8 Operating mode
F Constant value (a setpoint value)

V Variable (setpoint value range)

M Modbus RTU

9 Signal voltage range (only with operating mode F, V)

0 0 – 10 V DC

2 2 – 10 V DC

10 Operating values for factory setting

Volume flow rates [m³/h or l/s]

 q_{vconst} (only with operating mode F)

 q_{vmin} (only with operating mode V, M)

 q_{vmax} (only with operating mode V, M)

11 Volume flow unit

m³/h

l/s

Variants

Compact controller XM0 for TVE

Compact controller XM0 for TVE (with attached terminal cover)

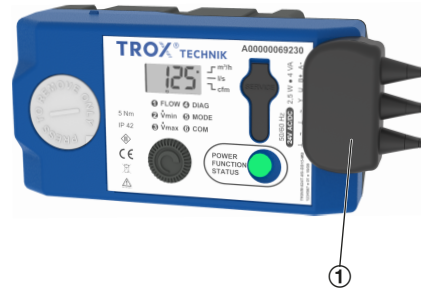
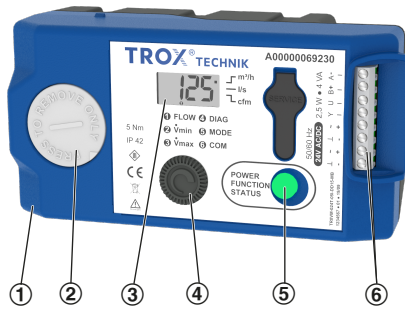

- ① Compact controller
- ② Release button
- ③ Display
- ④ Control element Selection Options/Setting values
- ⑤ Control element Selection Menu entry
- ⑥ Terminal

- ① Terminal cover (Part of the supply package)

Technical data

Compact controllers for VAV terminal units

VAV terminal units	Type of installation component	Part number
TVE	TROVM-024T-05I-DD15-MB	A00000069230

Compact controller XM0 for TVE



TROVM-024T-05I-DD15-MB

Supply voltage (AC)	24 V AC $\pm 20\%$, 50/60 Hz
Supply voltage (DC)	24 V DC $\pm 20\%$
Power rating (AC)	4 VA max.
Power rating (DC)	Max. 2.5 W
Running time for 90°	100 s
bus connection	Modbus RTU, RS485
Number of nodes	128
Adjustable communication parameters	1200 – 115,200 Bd
	Start bit: 1
	Data bits: 8
	Stop bits: 1 or 2
	Parity: None, Even, Odd
Setpoint / actual value interface (Modbus)	via Modbus register list
Cable termination	externally required
Setpoint value signal input (analogue optional)	0 – 10 V DC, $R_a > 100 \text{ k}\Omega$
	or 2 - 10V DC $R_a > 50 \text{ k}\Omega$
Actual value signal output	0 – 10V DC or 2 – 10V DC; max. 5mA
IEC protection class	III (protective extra-low voltage)
Protection level	IP 42 (with attached terminal cover)
EC conformity	EMC to 2014/30/EU

Interface configuration of control components

Depending on the setting, the Modbus communication interface or the analogue interface are available for the setpoint value specification of volume flow rates. The so-called interface mode is preset at the factory according to the order code and can be adjusted on-site by setting via the menu navigation or the Modbus registers.

Typical interface configuration

XMO	Setpoint value setting via:	Actual values via:	corresponds to order key option	Menu configuration (Mode)
Analog operation	Analogue 0 – 10 V	Analogue 0 – 10 V	V or F	CA0
Analog operation	Analogue 2 – 10 V	Analogue 2 – 10 V	V or F	CA2
Modbus operation	Modbus register setpoint	Modbus register actual value or analog 2 - 10V	M	CB

A special configuration of the Modbus register interface mode enables the configuration of a mixture of Modbus and analogue modes. For more information, see the description of the interface mode in Modbus register 122.

Supplementary use of the Modbus interface in analogue mode

In analogue mode, only the setpoint value settings are analysed on the analogue input. A setpoint value setting via the Modbus interface (register 0) is not possible. Any write attempts are acknowledged with an error response. Regardless of the selected interface configuration, however, the other Modbus registers can be used. In this way, the volume flow rate actual value and blade position operating values can be read out from a higher-order central BMS with local control via an analogue signal and a connected Modbus, or central override control can also be triggered.

Communication interface Modbus RTU (operating mode M)

Register	Meaning	Access right	Storage
0 Installation components	Volume flow rate setpoint value [%] Reference: $V_{min} - V_{max}$ ($q_{vmin} - q_{vmax}$) Resolution: 0 – 10000 Volume flow rate setpoint: 0.00 – 100.00%	R, W	RAM
1	Activation of an override control; 0 = no; 1 = Open; 2 = Close; 3 = V_{min} ; 4 = V_{max}	R, W	RAM
2	Command triggering 0 = none; 1 = adaptation; 2 = test run; 4 = controller reset	R, W	RAM
4	Current damper blade position [%] Resolution: 0 – 10000 Damper blade position: 0.00 – 100.00%	R	RAM
5	Current damper blade position [°] Reference: without decimal places	R	RAM
6	Current actual volume flow rate [%]	Compact controller	RAM

	Resolution: Vnom Resolution: 0 – 10000 Volume flow rate actual value: 0.00 – 100.00%	analogue and Modbus RTU Display	
7	Current actual volume flow rate in volume flow unit [m³/h], [l/s], [cfm] acc. Register 201	R	RAM
8	Voltage value at analog input Y [mV]	R	RAM
103	Firmware version	R	Flash
104	Status information (Bit = 1 active, bit = 0 inactive) Bit 2 mechanical overload Bit 8 internal activity e.g. Test run, adaptation Bit 10 bus timeout monitoring triggered	R	RAM
105	Work area limitation: Operating parameters Vmin (qvmin) [%] Resolution: Vnom Resolution: 0 – 10000 Vmin: 0.00 – 100.00%	R, W	EEPROM
106	Work area limitation: Operating parameters Vmax (qvmax) [%] Resolution: Vnom Resolution: 0 – 10000 Vmax: 0.00 – 100.00%	R, W	EEPROM
108	Behavior on bus timeout; 0 = no; 1 = To; 2 = open; 3 = qvmin; 5 = qVmax	R, W	EEPROM
109	Definition bus timeout [s]	R, W	EEPROM
110	Vnom in volume flow unit [m³/h], [l/s], [cfm]	R	EEPROM
120	Definition work area: operating parameters Vmin (qvmin) in volume flow unit [m³/h], [l/s], [cfm] acc. Register 201	R, W	EEPROM
121	Definition work area: operating parameters Vmax (qvmax) in volume flow unit [m³/h], [l/s], [cfm] acc. Register 201	R, W	EEPROM
122	Interface definition (Interface mode) For assignment see separate table	R, W	EEPROM
	Modbus address (user address)	R, W	EEPROM

130 *			
201	Volume flow unit 0 = l/s; 1 = m ³ /h; 6 = cfm	R, W	EEPROM
231	<p>Adjustment mode:</p> <p>Bit 0 defines the characteristic selection of the analogue interface.</p> <p>Bit 0 = 0 characteristic: 0 – 10 V</p> <p>Bit 0 = 1 characteristic: 2 – 10 V</p> <p>Bit 4 defines the actual value signal as volume flow rate actual value or damper position.</p> <p>Bit 4 = 0 volume flow rate actual value</p> <p>Bit 4 = 1 Damper blade position</p> <p>All other bits must not be changed.</p>	R, W	EEPROM
568	Modbus parameter kit communication settings: baud rate, parity, stop bits, assignment see separate table	R, W	EEPROM
569	Modbus communication settings: Modbus Response Time = 10 ms + delay; with delay= 3 ms × register value 0 – 255	R, W	EEPROM
572	<p>Setting of switching threshold for override control CLOSED via control signal for signal voltage range 2 – 10 V:</p> <p>Setting range 0.5 V – 1.8 V</p> <p>Default value 0.8V (register value = 20)</p> <p>Resolution: 1 setting unit = 40mV</p>	R, W	EEPROM

* Factory setting: Modbus address 1

R = Register can be read

R,W = Register can be read and written

RAM = Register value temporary

EEPROM = Register value not temporary, but saved permanently (max. 1 million. write processes)

Detailed information on register 122 (communication interface setpoint/actual value - Interface Mode)

Register value	Signal input	Feedback signal
0 Installation components	Analogue (0) 2 – 10 V	(0)2 – 10 V
1	Modbus via Register 0	(0)2 – 10 V
2	Modbus via Register 0	Register 10
3	Analogue (0) 2 – 10 V	Register 10

Detailed information on register 568 (Modbus communication parameters)

Register value	Display setting value	Baud rate	Parity	Stop bits
0 Installation components	1	1200	None	2
1	2	1200	Straight	1
2	3	1200	Uneven	1
3	4	2400	None	2
4	5	2400	Straight	1
5	6	2400	Uneven	1
6	7	4800	None	2
7	8	4800	Straight	1
8	9	4800	Uneven	1
9	10	9600	None	2
10	11	9600	Straight	1
11	12	9600	Uneven	1
12	13	19200	None	2
13	14	19200	Straight	1
14	15	19200	Uneven	1
15 **	16	38400	None	2
16	17	38400	Straight	1
17	18	38400	Uneven	1
18	19	1200	None	1
19	20	2400	None	1
20	21	4800	None	1
21	22	9600	None	1
22	23	19200	None	1
23	24	38400	None	1
24	25	76800	None	1
25	26	115200	None	1
26	27	76800	None	2
27	28	76800	Straight	1
28	29	76800	Uneven	1
29	30	115200	None	2
30	31	115200	Straight	1
31	32	115200	Uneven	1

** factory setting: Modbus communication parameters

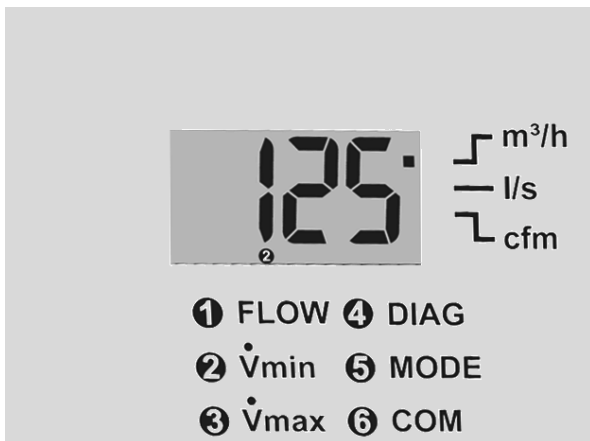
XM0, Display

Display range of functions
Display functions

- Volume flow rate actual value (unit optionally m³/h, l/s, cfm)
- 3-character display with position valuation labelling
- Status and error display for various operating modes, including display of activated override control, display of diagnostic function

Parameterisation functions

- Adjustment option for the unit of the volume flow rate display m³/h, l/s, cfm
- Adjustment option for the work area $q_{v\min}$, $q_{v\max}$
- Selection of the interface configuration Modbus or analogue including signal voltage range 0 – 10 V or 2 – 10 V DC
- Adjustment option for Modbus communication settings (address, baud rate, stop bits, parity)

Diagnosis

- Activation of a test run
- Activation of override controls Open, Closed, $q_{v\min}$, $q_{v\max}$, motor stop (note prioritisation)
- Display of the voltage value on the analogue input

Commissioning

After installation, wiring and connection of the supply voltage

- When using the Modbus interface: set the Modbus communication parameters via the integrated menu, the air terminal unit is then ready
- Setpoint value setting via Modbus register
- When using the analogue interface: air terminal unit is immediately ready for use
- Comply with volume flow rate control range from 4 – 100 % of $q_{v\text{enn}}$; do not set a volume flow rate which is below the minimum flow rate of the control unit
- Only briefly remove the protective cap of the control component during wiring

Product details

Modbus mode (order code, operating mode M)

For smooth data exchange in the Modbus RTU network, the communication parameters and user address must be set for the Modbus interface.

The interface offers standardised Modbus register access to the available data points via the functions ReadHoldingRegister (3) and WriteSingleRegister (6).

Setpoint value setting

- In the operating mode M, the setpoint value is only set by specifying the volume flow rate set point value [%] in the Modbus register 0.
- The transferred percentage value refers to the volume flow rate range specified by $q_{vmin} - q_{vmax}$.
- Volume flow rate range $q_{vmin} - q_{vmax}$ is pre-set in the factory according to the order code entries.
- Subsequent adjustment of q_{vmin} or q_{vmax} is possible in the setup menu on the display, with the adjustment device or using the Modbus interface.

Actual value as feedback for monitoring or tracking control

- In Modbus register 7, the current actual volume flow rate can be called up in the set volume flow rate unit (register 201).
- In addition to the volume flow rate actual value, further information on other Modbus registers can be read out. For overview, see register list.
- For diagnostic purposes, the volume flow rate actual value can be tapped at terminal U in Modbus mode. The volume flow rate range $0 - q_{vnom}$ here always corresponds to the signal voltage range of 2 – 10V DC.

Override control

For special operating situations, the volume flow controller can be put in a special operating mode (override control). The following are possible: control q_{vmin} , control q_{vmax} , damper blade in the OPEN position or damper blade CLOSED.

Override control via the Modbus

This is set via the Modbus register 1.

Override control via bus timeout monitoring

If the Modbus communication fails for a stipulated time period, a pre-defined operating mode q_{vmin} , q_{vmax} , OPEN or CLOSED can be activated.

- The override control to be activated upon bus failure is specified via register 108.
- The time period after which override control is activated upon bus failure is specified via register 109.
- Each Modbus communication resets the timeout of the bus failure monitoring.

Override controls for diagnostic purposes

Activation of the diagnostic menu on the display of the controller or via the service tools (adjustment device, PC software).

Prioritisation of various setting options

Settings for override controls via service tools are prioritised over Modbus settings.

- Highest priority: settings via the service connector (adjustment device, PC software) for test purposes
- Lowest priority: settings via Modbus 1 or the diagnostic menu on the controller

Einbau und Inbetriebnahme

Analogue mode 0 – 10V DC or 2 – 10V DC (order code, operating mode V, F)

The analogue interface can be adjusted for the signal voltage range 0 – 10V DC or 2 – 10V DC.

The assignment of the volume flow rate setpoint value or actual value for voltage signals is shown in the characteristic curves.

- The set signal voltage range always applies equally for setpoint value and actual value signals.
- The signal voltage range is pre-set in the factory according to the order code entries.
- The signal voltage range can be adjusted by others in the setup menu on the display or using the adjustment device.

Setpoint value setting

- In operating mode V (variable mode), the setpoint value is only specified with an analogue signal on terminal Y. Setpoint value settings via the Modbus register 0 are rejected.
- The selected signal voltage range 0 – 10V or 2 – 10V DC is assigned to the volume flow rate range $q_{vmin} - q_{vmax}$ a change packet.
- Volume flow rate range $q_{vmin} - q_{vmax}$ is pre-set in the factory according to the order code entries.
- Subsequent adjustment of q_{vmin} or q_{vmax} is possible in the setup menu on the display or using the adjustment device.

- In operating mode F (constant value mode), an analogue signal on terminal Y is not required.
- It is controlled by the volume flow rate constant value set by q_{vmin} .
- Volume flow rate q_{vmin} is pre-set in the factory according to the order code entry.
- Subsequent adjustment of q_{vmin} is possible in the setup menu on the display or using the adjustment device.

Actual value as feedback for monitoring or tracking control

- On the terminal U, the actual volume flow rate measured by the controller can be tapped as a voltage signal.
- The selected signal voltage range 0 – 10V DC or 2 – 10V DC is shown in the volume flow rate range 0 – q_{vnom} .
- In analogue mode (operating mode V, F) there is also the option of querying operating data using the Modbus interface.

Override control

For special operating situations, the volume flow controller can be put in a special operating mode (override control). The following are possible: control q_{vmin} , control q_{vmax} , damper blade in the OPEN position or damper blade CLOSED.

Override controls via signal input Y

By appropriate wiring at the signal input Y, the positive controls can be activated according to the connection diagrams by wiring with external switching contacts / relays (see wiring examples). OPEN and CLOSED are only available if the controller is supplied with alternating current (AC).

Override control CLOSED via control signal on control signal Y

- with signal voltage range 0 – 10 V DC: CLOSED is activated when $q_{vmin} = 0$ set **and** control signal Y < 0.3V DC.
- with signal voltage range 2 – 10V DC: CLOSED is activated when control signal is Y < 0.8V ^(*) DC.
(*) 0.8V = factory setting

Override controls in analogue mode via Modbus interface

If the Modbus interface is additionally connected in analogue mode, an override control can also be specified via Modbus register 1.

Override control for diagnostic purposes

Activation via the diagnostic menu in the display of the controller or the service tools (adjustment device, PC software).

Prioritisation of various setting options

Various override control options are prioritised as follows by the controller:

- Highest priority: settings via the service connector (adjustment device, PC software) for test purposes
- Medium priority: settings via Modbus register 1 or the diagnostic menu on the controller
- Lowest priority: settings via wiring on the Y signal input of the controller

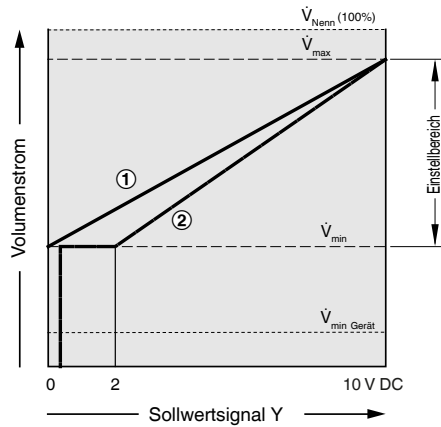
XM0, Characteristic of the setpoint value signal

- ① Signal voltage range 0 – 10 V DC
- ② Signal voltage range 2 – 10 V DC

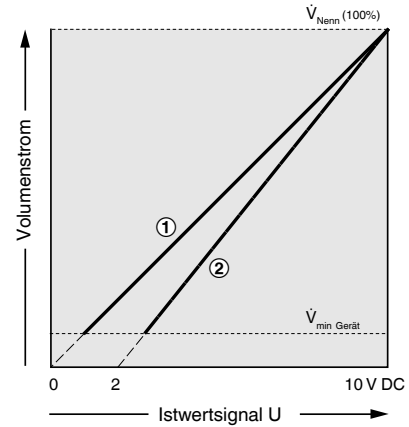
XM0, Characteristic of the actual value signal

- ① Signal voltage range 0 – 10 V DC
- ② Signal voltage range 2 – 10 V DC

Calculation volume flow rate setpoint value at 0 – 10 V:

0 – 10 V DC

$$\dot{V}_{\text{Soll}} = \frac{Y}{10} (\dot{V}_{\text{max}} - \dot{V}_{\text{min}}) + \dot{V}_{\text{min}}$$

Calculation volume flow rate actual value at 0 – 10 V:

0 – 10 V DC

$$\dot{V}_{\text{Ist}} = \frac{U}{10} \dot{V}_{\text{Nenn}}$$

Calculation volume flow rate setpoint value at 2 – 10 V:

2 – 10 V DC

$$\dot{V}_{\text{Soll}} = \frac{Y-2}{8} (\dot{V}_{\text{max}} - \dot{V}_{\text{min}}) + \dot{V}_{\text{min}}$$

Calculation volume flow rate actual value at 2 – 10 V:

2 – 10 V DC

$$\dot{V}_{\text{Ist}} = \frac{U-2}{8} \dot{V}_{\text{Nenn}}$$

Terminal connections with analogue operation 0 – 10 V or 2 – 10 V

Terminal connections for Modbus operation

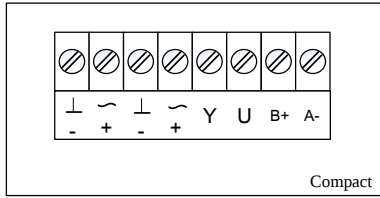

⊥, - = Ground, neutral
 ~, + = Supply voltage 24 V
 Y = Setpoint value signal 0 – 10 V DC or 2 – 10 V DC and override control
 U = Actual value signal 0 – 10 V DC or 2 – 10 V DC
 B+ = Modbus RTU (no setpoint value setting via Modbus)
 A- = Modbus RTU (no setpoint value setting via Modbus)

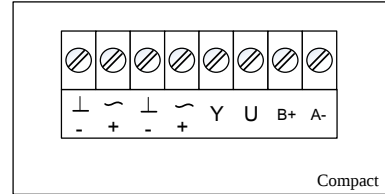

⊥, - = Ground, neutral
 ~, + = Supply voltage 24 V
 Y = Analogue input
 U = Actual value signal 2 – 10 V DC
 B+ = Modbus RTU
 A- = Modbus RTU

XM0, Control input signal analogue and override control, voltage signal 0 – 10 V DC

XM0, Control input signal analogue and override control, voltage signal 2 – 10 V DC

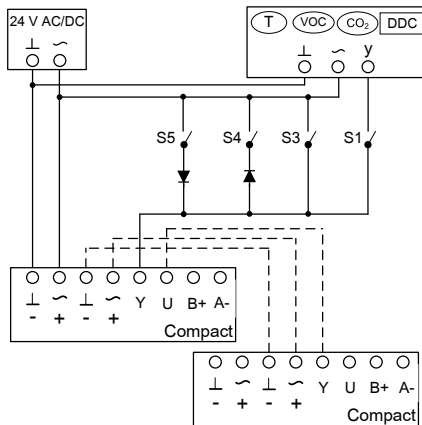

Switch functions
 All OPEN: Minimum volume flow rate qvmin
 S1 = Room temperature control
 S3 = maximum volume flow rate qvmax
 S4 = Damper blade CLOSED (only with supply voltage 24 V AC)
 S5 = Damper blade OPEN (only with supply voltage 24 V AC)
 T, VOC, CO2, DDC = Setpoint value setting

When combining several override controls the switches must be interlocked to prevent short-circuits. Diode: e.g. 1N 4007

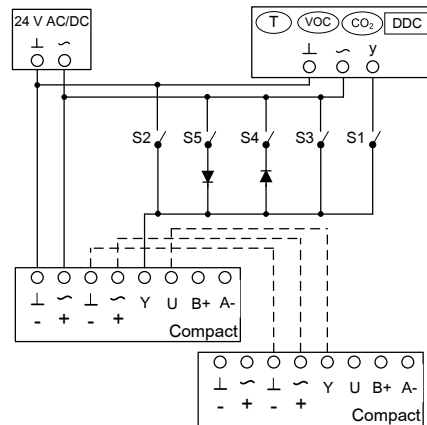

Switch functions
 All OPEN: Minimum volume flow rate qvmin
 S1 = Room temperature control
 S2 = Damper blade CLOSED
 S3 = maximum volume flow rate qvmax
 S4 = Damper blade CLOSED (only with supply voltage 24 V AC)
 S5 = Damper blade OPEN (only with supply voltage 24 V AC)
 T, VOC, CO2, DDC = Setpoint value setting

When combining several override controls the switches must be interlocked to prevent short-circuits. Diode: e.g. 1N 4007

Explanation

q_{vnom}
[m³/h]; [l/s]

Nominal volume flow rate (100 %): The value depends on product type and nominal size. Values are published on the internet and in technical leaflets, and stored in the Easy Product Finder design software. Reference value for calculating percentages (e.g. q_{vmax}). Upper limit of the setting range and maximum volume flow rate setpoint value for the VAV terminal unit.

$q_{vmin Unit}$
[m³/h]; [l/s]

Technically possible minimum volume flow rate: The value depends on product type, nominal size and control component (attachment). Values are stored in the Easy Product Finder design software. Lower limit of the setting range and minimum volume flow rate setpoint value for the VAV terminal unit. Depending on the controller, setpoint values below $q_{vmin unit}$ (if q_{vmin} equals zero) may result in unstable control or shut-off.

q_{vmax}
[m³/h]; [l/s]

Upper limit of the operating range for the VAV terminal unit that can be set by customers: q_{vmax} can only be smaller than or equal to q_{vnom} . In case of analogue signalling to volume flow controllers (which are typically used), the set maximum value (q_{vmax}) is allocated to the setpoint signal maximum (10 V) (see characteristic).

q_{vmin}

[m³/h]; [l/s]

Lower limit of the operating range for the VAV terminal unit that can be set by customers: q_{vmin} should be smaller than or equal to q_{vmax} . Do not set q_{vmin} smaller than $q_{vmin unit}$, otherwise the control may become unstable or the damper blade may close. q_{vmin} may equal zero. In case of analogue signalling to volume flow controllers (which are typically used), the set minimum value (q_{vmin}) is allocated to the setpoint signal minimum (0 or 2 V) (see characteristic).

q_v
[m³/h]; [l/s]

Volume flow rate

Δ_{pst}
[Pa]

Static differential pressure

$\Delta_{pst min}$
[Pa]

Static differential pressure, minimum: The static minimum differential pressure is equal to the pressure loss of the VAV controller when the damper blade is open, caused by flow resistance (damper blade). If the pressure on the VAV controller is too low, the setpoint volume flow rate may not be achieved, not even when the damper blade is open. Important factor in designing the ductwork and in rating the fan including speed control. Sufficient differential pressure must be ensured for all operating conditions and for all controllers, and the measurement point or points for speed control must have been selected accordingly to achieve this.